

QIS Series

Φ 1000 GPM / 3785 LPM

μ up to 600 cP

P 130 psi / 9 bar
300 ft / 91 m

T 120 °C / 248 °F

The QIS is a new sanitary centrifugal pump with an Internal seal, ideal for sanitary and non-sanitary applications, perfect for the food, beverage and pharmaceutical industries. Completely redesigned for greater efficiency and hygiene.

CHARACTERISTICS

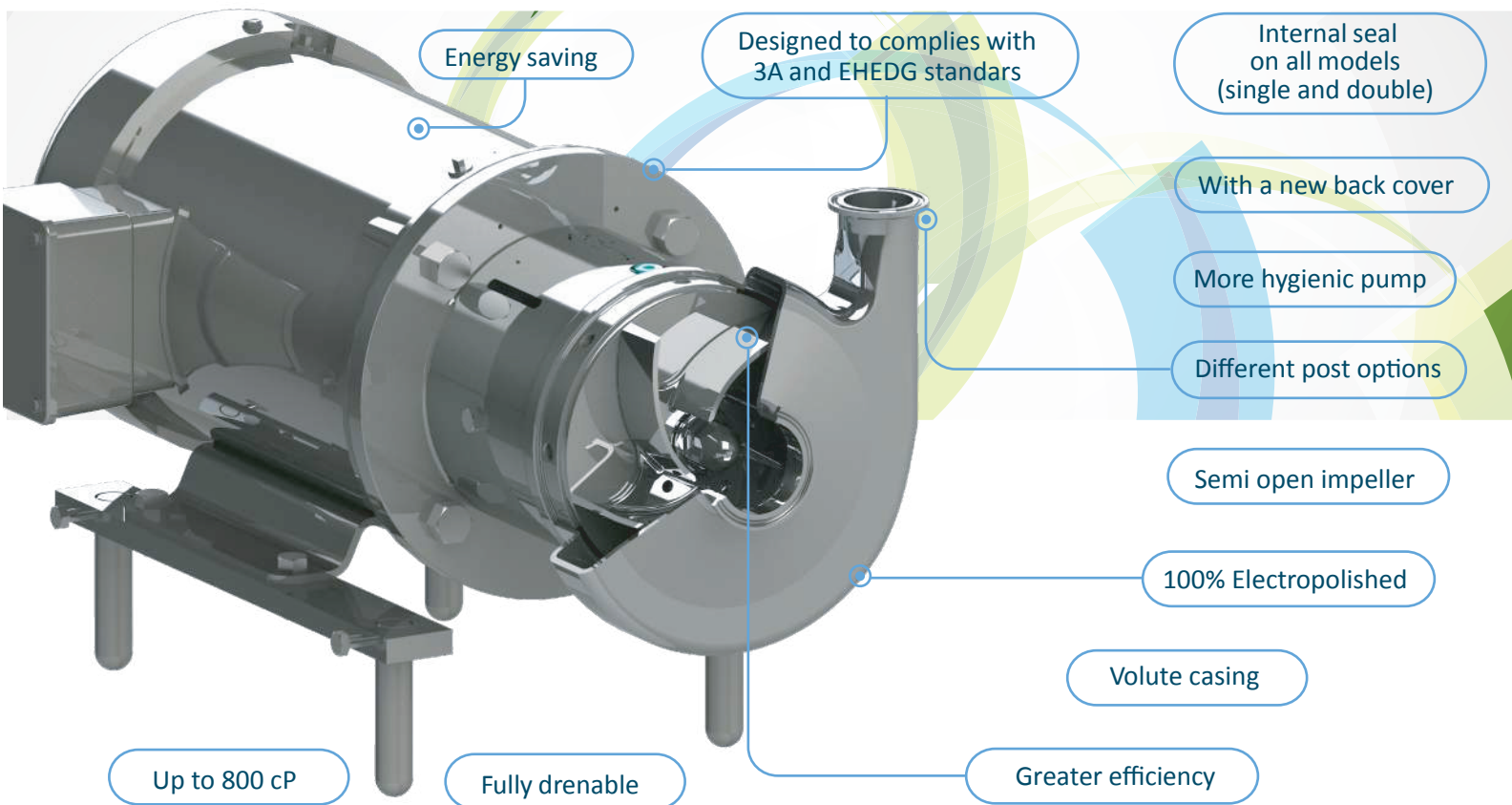

QAT: Q-Pumps Air Tank

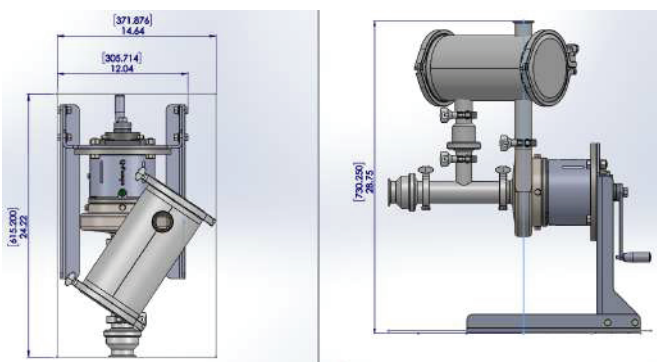

This accesorie is special designed for any QC and QIS series pump to convert them in a self priming pump ideal for handling air, upto 60%, principally used as CIP return pump.

APPLICATIONS

- Dairy
- Water
- Soda
- Juice
- Alcoholic beverages
- Beer